



**SISTEMA MODULARE
MODULAR SYSTEM
SYSTEMES MODULAIRES**



I AVVERTENZE:

SONO VIETATE MODIFICHE ALL'APPARECCHIO SENZA NOSTRA AUTORIZZAZIONE

- La sicurezza e il corretto funzionamento dell'apparecchio sono garantiti solo rispettando le normative elettriche e queste istruzioni; pertanto è necessario conservarle.
- L'installazione deve essere eseguita da personale qualificato.
- Utilizzare solo ricambi originali ARCLUCE.



Direttiva 2002/96/CE (Rifiuti di Apparecchiature Elettriche ed Elettroniche - RAEE).
L'etichetta con il cassonetto barrato indica che il prodotto non deve essere smaltito come un normale rifiuto urbano, ma attraverso una raccolta separata; questo al fine di evitare potenziali conseguenze negative per l'ambiente e per la salute umana. Per maggiori dettagli sui centri di raccolta disponibili contattare l'ufficio governativo locale o il rivenditore di prodotto.



In caso di manutenzione togliere la tensione.

Queste istruzioni e altra documentazione tecnica continuamente aggiornata è disponibile sul sito www.arcluce.it.

ENG WARNING:

ANY MODIFICATION TO THIS FITTING IS FORBIDDEN WITHOUT OUR AUTHORIZATION

- The safety and the proper functioning of the fitting is guaranteed only respecting the electrical Standards and this mounting instructions; so it's necessary to keep them.
- Installation should be carried out by a suitable qualified person.
- Only use original ARCLUCE spare parts.



Directive 2002/96/CE (Waste Electrical and Electronic Equipment - WEEE)
The crossed out wheeled bin label that this product should not be disposed how the normal household waste stream, but with a separate collection; this in order to prevent potential negative consequences for the environment and the human health. For more details on available collection facilities please contact your local government office or the dealer where you purchased this product.



Turn power off before maintenance.

This data sheet and other technical documents continually updated can be accessed at www.arcluce.it.

FR AVERTISSEMENT:

TOUTE MODIFICATION DE CET APPAREIL, SANS NOTRE AUTORISATION, EST INTERDITE

- La sécurité et le fonctionnement correct de l'appareil sont garantis respectant les normes électriques et ces instructions; il est donc nécessaire de les conserver.
- L'installation doit être faite par personnel qualifié.
- Utiliser seulement pièces de rechange originales ARCLUCE.



Directive 2002/96/CE (Déchets d'Equipments Electriques et Electroniques - DEEE).
L'étiquette avec la case cochée indique que le produit ne doit pas être traité comme déchet ménager, mais à travers une collecte sélective; cette afin d'éviter d'éventuels dommages au niveau de l'environnement ou de la vie humaine. Pour plus de détails sur les sites de collecte existants, veuillez contacter l'administration local ou le détaillant auprès duquel vous avez acheté ce produit.



Avant toute intervention sur l'appareil fermer le courant.

Cette fiche d'instructions et d'autre documentation technique constamment mise au jour sont disponibles sur notre web-site www.arcluce.it.

INSTALLAZIONE - INSTALLATION - INSTALLATION

PESO MASSIMO UNIFORMEMENTE DISTRIBUITO SOPPORTABILE DAL MODULO STRUTTURALE VUOTO.
MAXIMUM BEARABLE WEIGHT (EVENLY DISTRIBUTED) FOR THE EMPTY MODULAR STRUCTURE.
POIDS MAXIMUM DISTRIBUE UNIFORMEMENT ADMIS POUR LE MODULE STRUCTUREL VIDE.

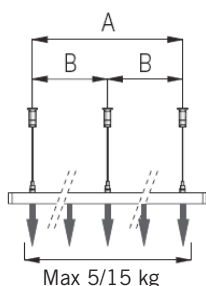

L	A	B	Kg
1000	900	900	10
2000	1800	900	10
2000	1800		6
3000	2800		5
3000	2800	1400	15

Morsetto per collegamento passante - max 10 A
Clamp for looped connection - max 10 A
Borne pour connexion passante - max 10 A

Canale porta cavi.
Cavi di alimentazione non inclusi.
Cable raceway.
Input cables not included.
Chemin porte câbles.
Câbles d'alimentation non inclus.



Massimo n.3 cavi 3G 1,5
Three 3G 1,5 cables maximum
3 câbles 3G 1,5 au maximum

A1713
Cassetta di derivazione
Junction box
Boîte de jonction

KG Max 1,0 kg

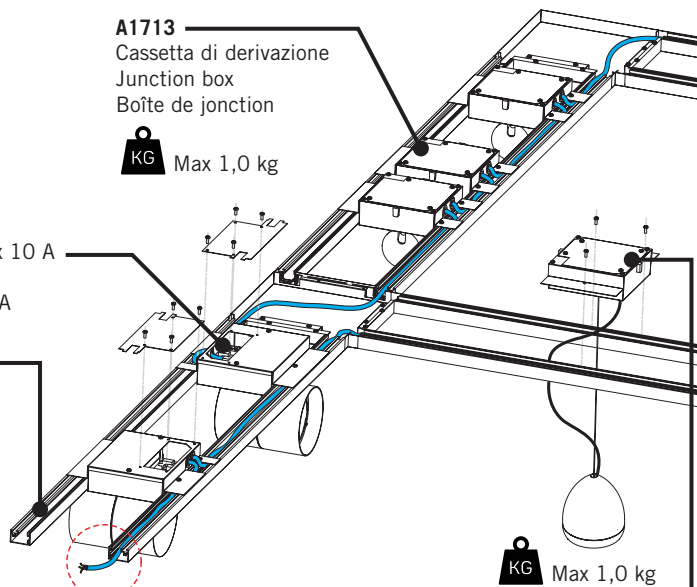

KG Max 1,0 kg

A1712 - A1714

Cassetta per apparecchi a sospensione
Adaptor for suspension apparatus
Boitier pour appareils suspendus

A1713

Morsetti per collegamento passante
max 10 A
Clamps for looped connection - max 10 A
Bornes pour connexion passante - max 10 A

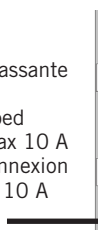

A1712 - A1714

1
Fune apparecchio
Fitting rope
Corpe appareil

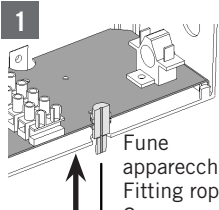

2
5 mm

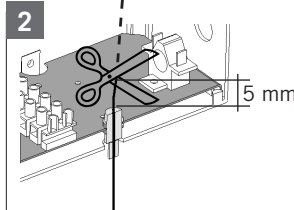

3
Cavo apparecchio
Fitting cable
Câble appareil

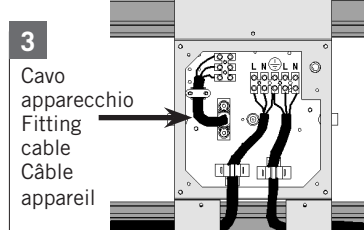

ACCESSORI - ACCESSORIES - ACCESSOIRES

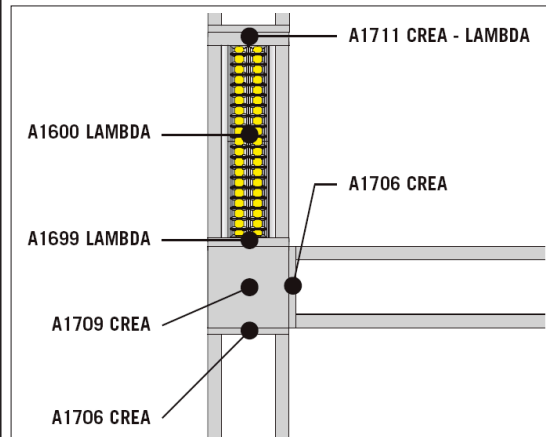

A1699 + A1707 / A1708 / A1709 / A1710

4		TC+ M4
A		TC+ 3,9
B		
C		

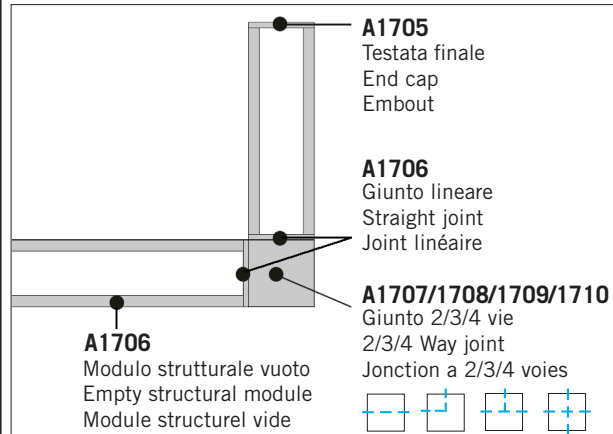
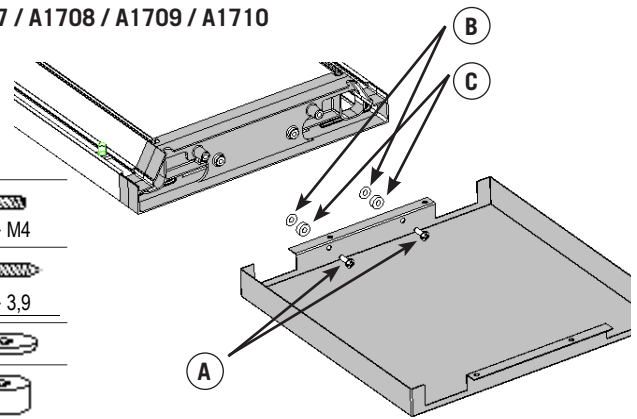

A1594

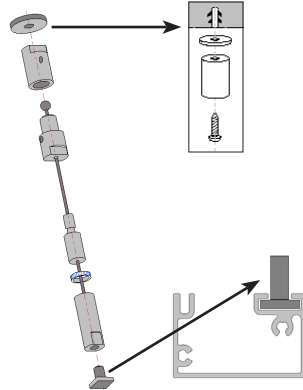

A1705

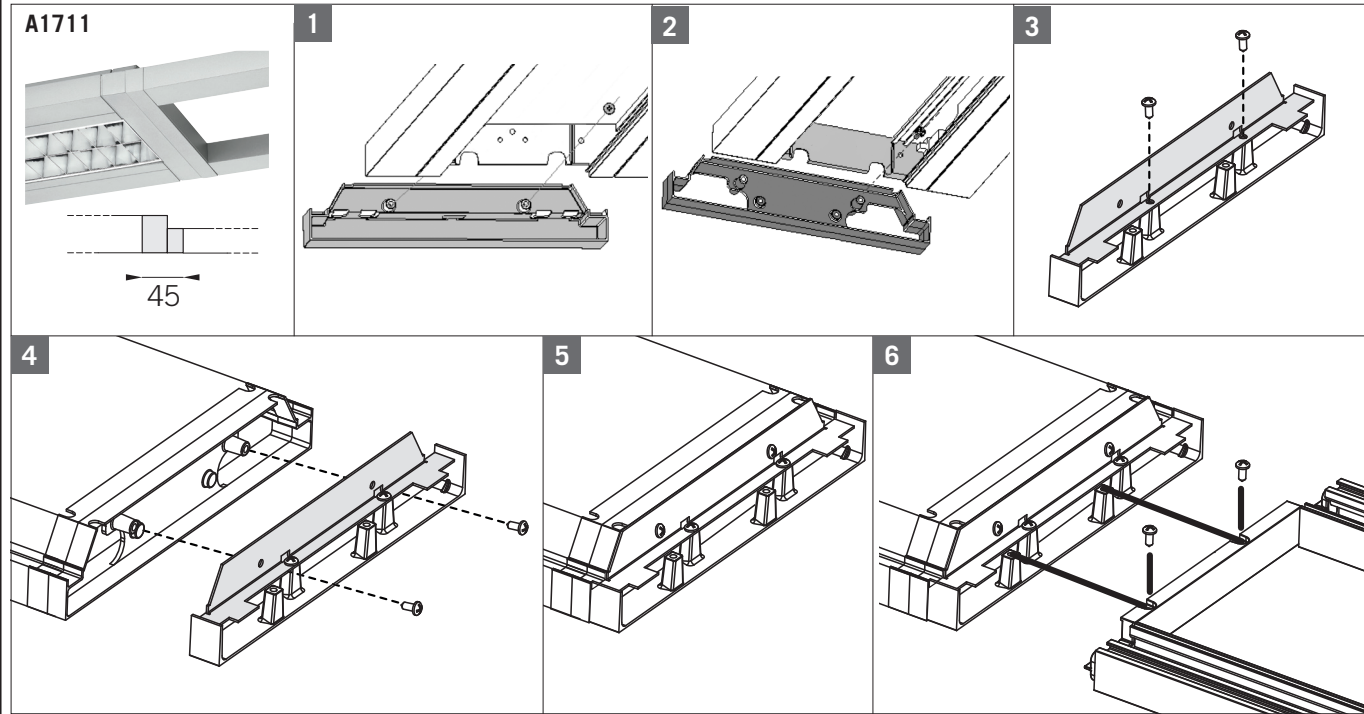
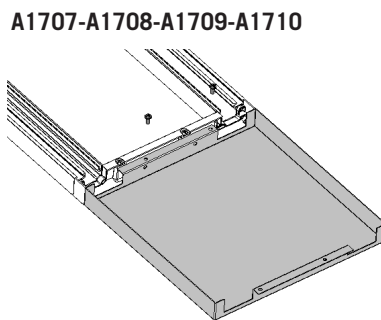
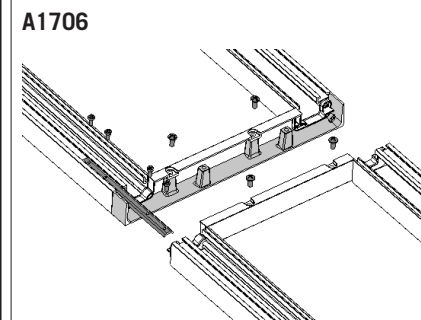
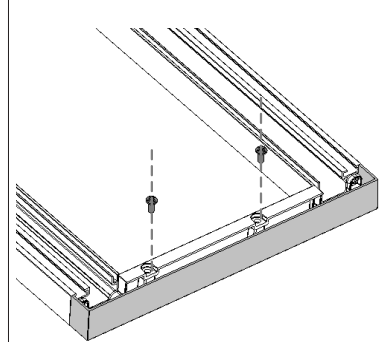

Data emissione: 2008.10.02

Stato di modifica: M3

Codice: 6551700.11